

School of Gauges

Spy Pro ESP Monitoring Downhole gauges

AUG 9th , 2022

Spy Pro ESP Systems



ELECTRIC
SUBMERSIBLE PUMP

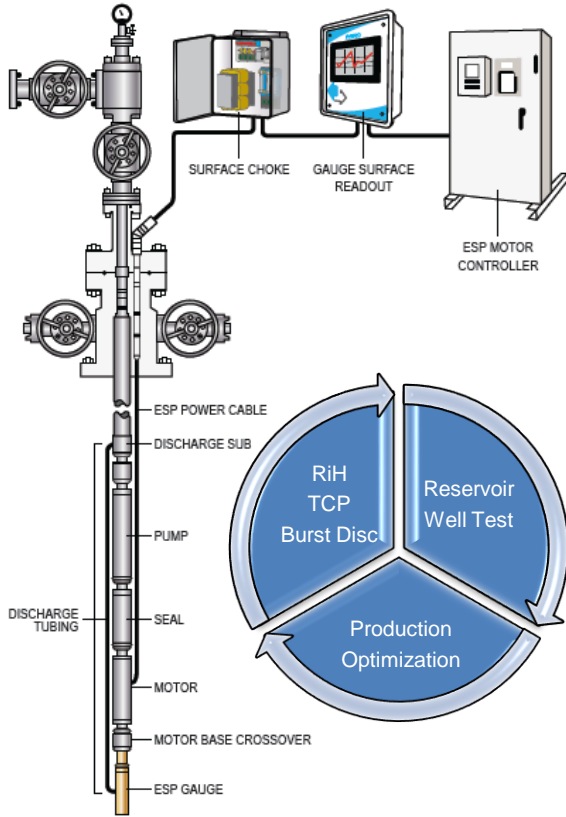

Offer a unique mechanical concept, with new electronic features, and channels of customizable fit for purpose data, that paired to the proper Surface Acquisition Unit, extends the monitoring capabilities of a typical ESP sensor to now serve a full cycle of monitoring applications needs required during the completion of a new ESP well.

Unique Mechanical Concept:

Welded Sealed Mechanic design eliminates the need of re-dressing and contamination.

Shorter and lighter design improves deployment in dogleg severity & rig less applications.

10K psi differential pressure extends use of gauge under HP conditions.

Extends the monitoring capabilities:

- Seal Integrity during Run In Hole
- Tubing Conveyed Perforating
- Burst Disk Rupture
- Reservoir and Well Testing
- Production Optimization

New electronic features:

ESP motor WYE point imbalance true downhole measurement allows understanding the trend of the electrical health of your ESP and easily determining if the gauge has: failed; can't communicate to surface due to high imbalance; or it's grounded. Gauge wiring to motor is fuse protected to avoid affecting the motor performance. **Motor winding temperature** can be read with RTD and Thermocouple options.

Financial Benefits:

- Reduce well Intervention parties, risk, liabilities and cost
- Optimize pump performance, run life and oil production
- Protect your people, pump and reservoir
- Eliminate pump shut down due to sensor troubleshooting

Customizable fit for purpose data:

uCommand enables, under VSD energized conditions or RiH, to tailor the channels of data to be collected, transmitted and stored at surface.

High Speed Data extends use of gauge in reservoir and well testing applications; and improves root cause analysis while still in the hole!

Intake Pressure being read internally from the motor oil, enables auditing the integrity of the seals and not being in contact with any harsh well fluids.

Monitor, Protect and/or Control from:

- Decrease fluid level at the pump intake (Pi)
- Increase motor temperature (Tm)
- Increase mechanical imbalance (V x,y)
- Increase current leakage (A)
- Decrease pump lifting efficiency (Pd)
- Increase gas locking and sand slugging (Pd, Vz)
- Increase motor WYE point voltage imbalance (V wye)*

Spy Pro ESP Systems

RTD or TC
motor temp

Internal pressure
transducer

Welded & Sealed

Shorter & Lighter

10K psia
diff. pressure

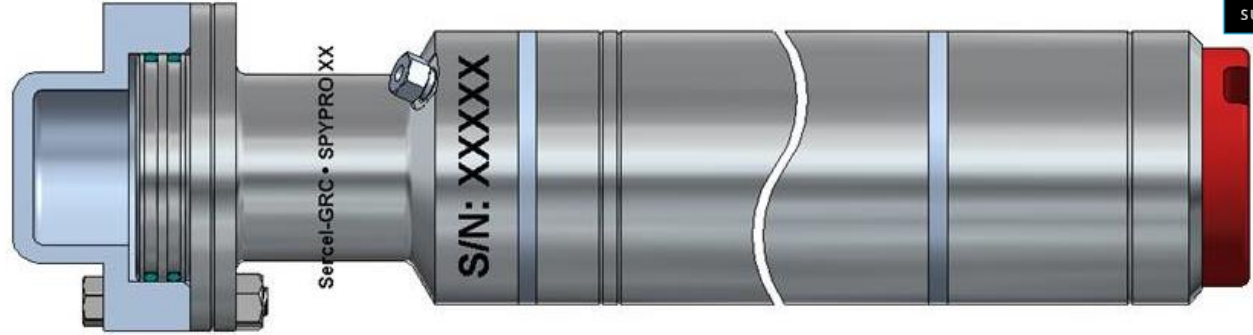

WYE point
voltage imbalance

WYE point
fuse protector

uCommand

LEASE PROOF

< OPEX
< Penalties

> higher run life
> increase ROI

Innovations - Ahead of the Curve -

Spy Pro ESP Systems

Spy Pro Series ESP System Specifications

Material	Carbon Steel 1026 or 17-4PH Stainless Steel per NACE MRO175
Temperature rating	125, 150 or 177 °C
Max working pressure	5,000 or 10,000 psi
Make up length & weight	17.86 in & 34 lb
Outside diameter	3.75 in.
Motor base connection	375 or 456 Series Flange Universal Motor Base
Sensor type	Piezoresistive
Tested insulation rating	5,000 VDC
High-voltage coupling requirement	Surface choke
Surface data acquisition	SPS-1500P RiH, SPS-1500 Interface or Data Pro Stand Alone



ELECTRIC
SUBMERSIBLE PUMP

Spy Pro Series ESP Monitoring Options	Spy Pro 10	Spy Pro 11		Units	Range	Resolution	Accuracy	Data Rate
Primary Parameters for essential pump and surveillance and protection								
Pump intake pressure	○	○		psia	0-10,000	0.1	± 0.1% FS	40s (2.5s option)
Pump discharge pressure		○		psia	0-10,000	0.1	±0.1% FS	40s (2.5s option)
Intake temperature	○	○		°C	0-177	0.1	1	40s (2.5s option)
Motor winding temperature	●	●	RTD or TC	°C	0-260	0.1	1	40s (2.5s option)
Vibration - x axis	○	○		g	0-16	0.01	1%	40s (2.5s option)
Vibration - y axis	○	○		g	0-16	0.01	1%	40s (2.5s option)
Vibration - z axis	●	●		g	0-16	0.01	1%	40s (2.5s option)
Predictive Parameters for preventive maintenance and effective workover management								
Current leakage	○	○		mA	0-50	0.001	0.05%	40s (2.5s option)
Line voltage	●	●		V	0-80	0.1	1%	40s (2.5s option)
Motor wye point voltage imbalance	●	●		V	0-400	0.1	1%	40s (2.5s option)
Data customization for application and user needs								
uCommand	●	●						

● Spy Pro Series market differentiating features

Spy Pro - Anatomy

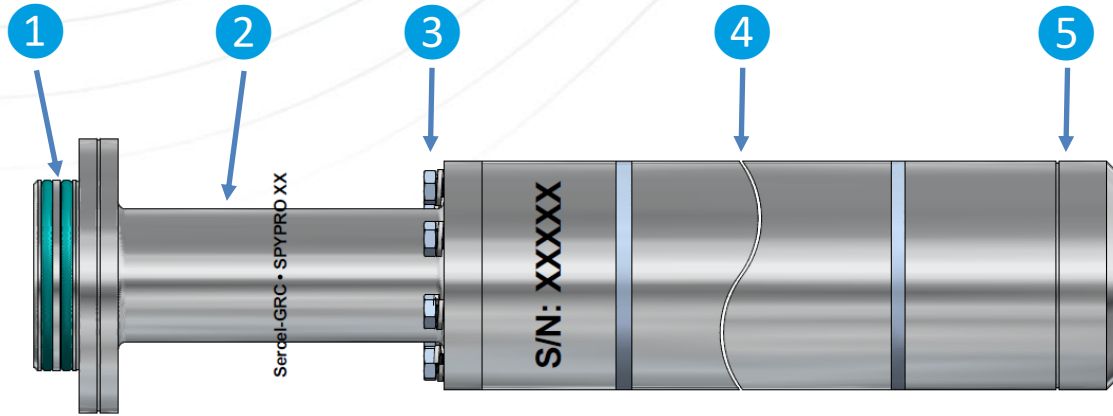

Item	Description / Descripción
1	2 x Viton O-ring #233 for 456 flange 079-0233-06 2 x Aflas O-ring #233 for 456 flange 10037397 2 x Viton O-ring #142 for 375 flange 079-0142-02 2 x Aflas O-ring #142 for 375 flange 10040281
2	FLANGE ADAPTER
3	KIT, 7/16 MONEL SCREWS/LOCK WASHERS
4	ENCLOSURE, 5 MODULE OPEN ONE SIDE
5	BOTTOM COUPLER

Spy Pro – Anatomy (Bottom coupler)

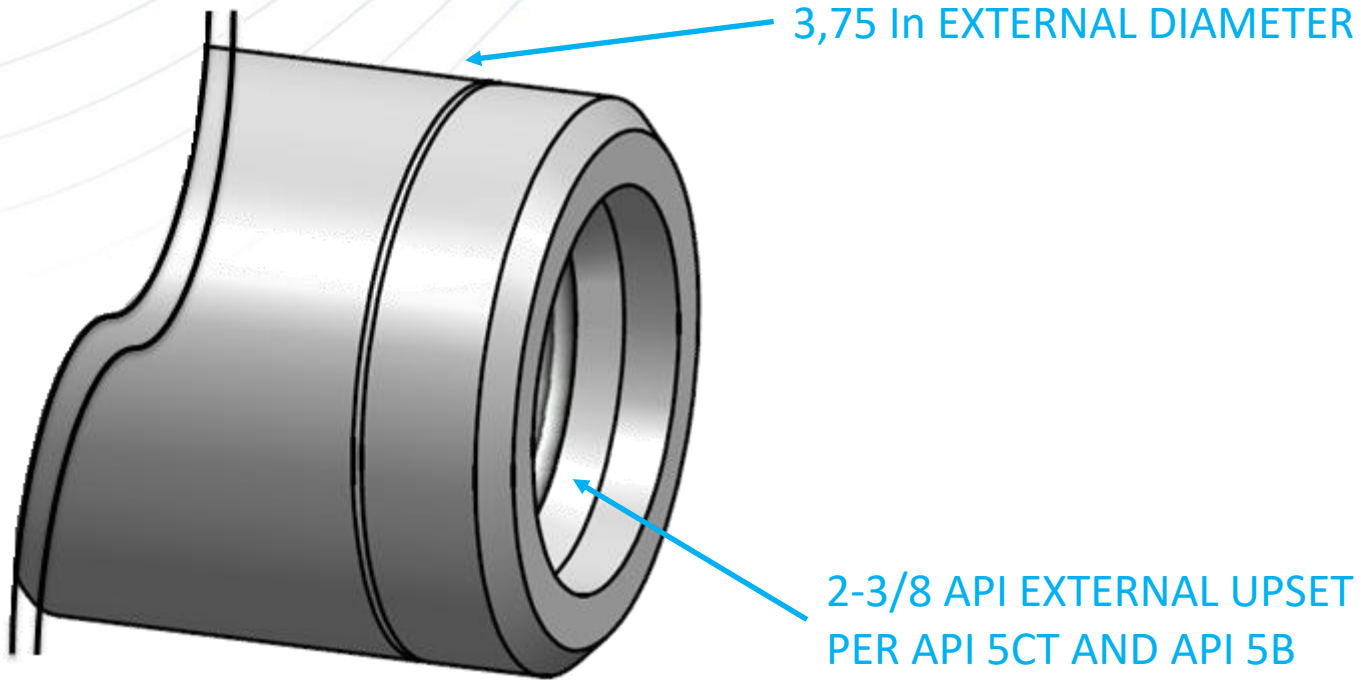

Spy Pro – Anatomy (Pressure head)

3,75 In EXTERNAL DIAMETER



Spy Pro 10

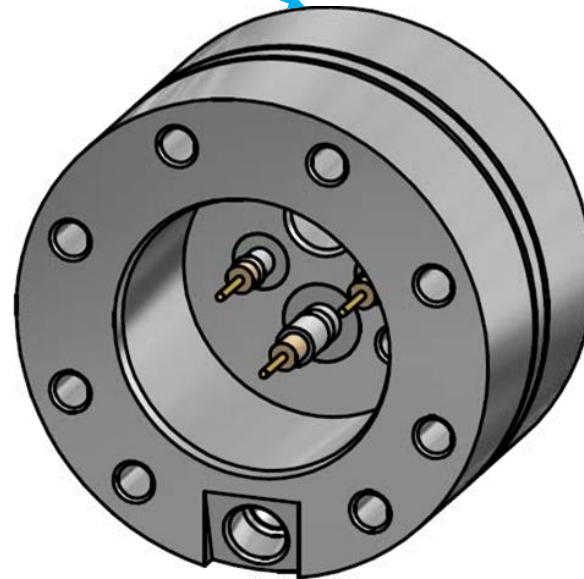

Spy Pro 11

Spy Pro - Anatomy (Tm connections)

Thermocouple Type J

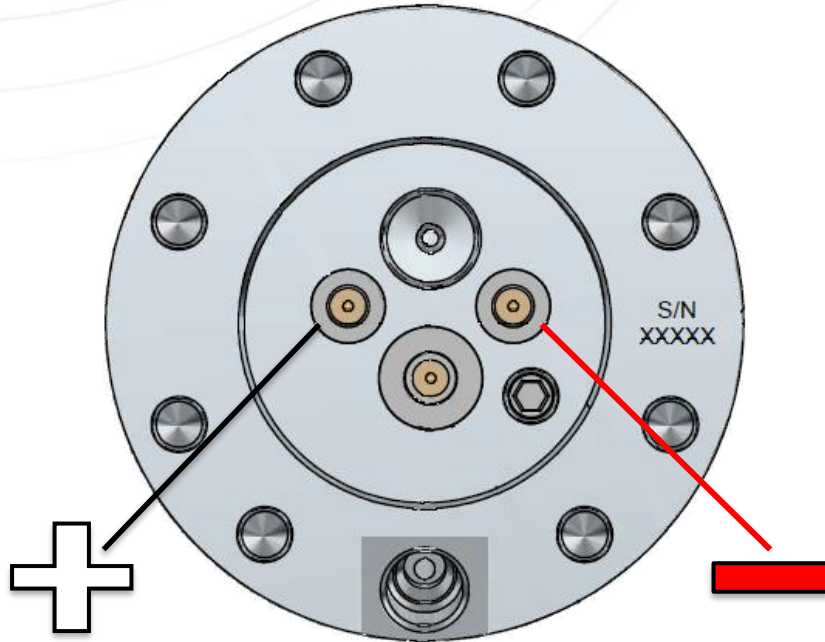

RTD

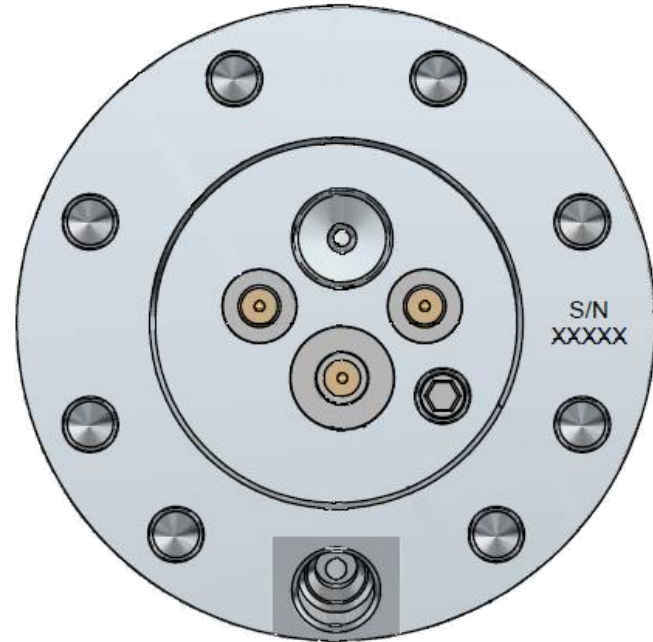

NO POLARITY!!!

Spy Pro – Anatomy (Intake Pressure)

› 9/16-18 UNF

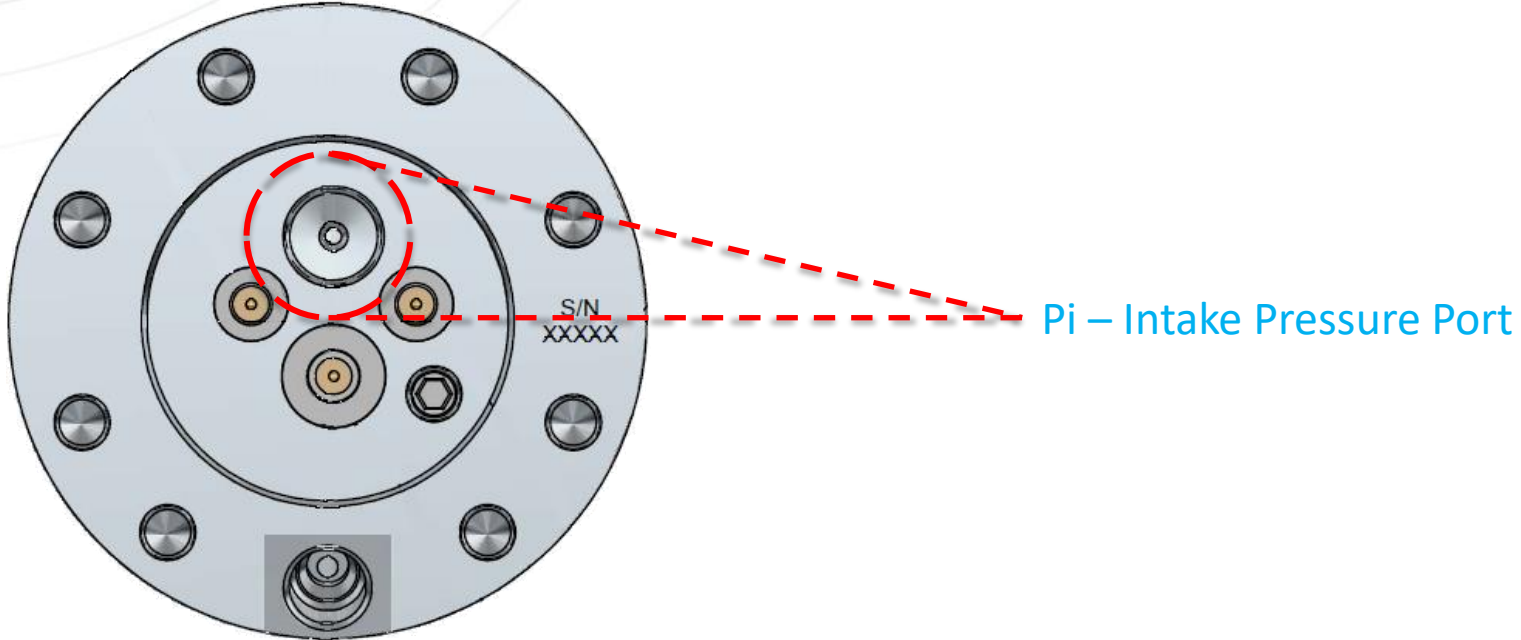

Spy Pro – Anatomy (Discharge Pressure)

> 1/2-20 UNF

Pd – Discharge Pressure Port

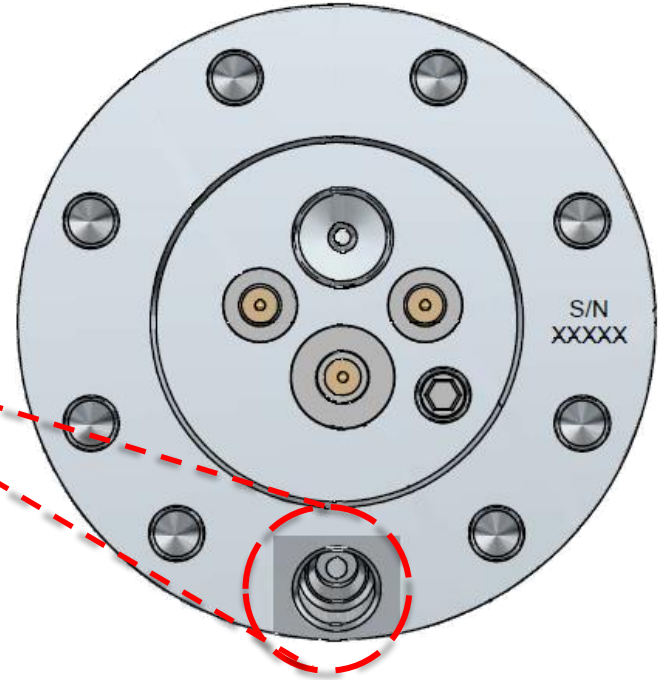

Spy Pro – Anatomy (Discharge Pressure)

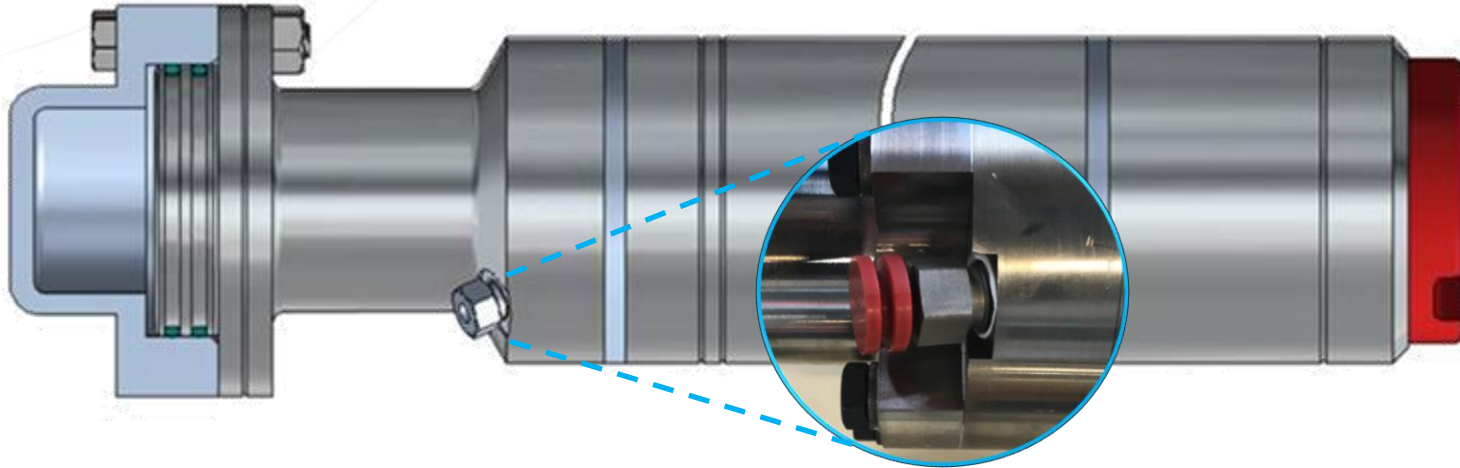

Cartridge, Swagelok SS-4FK-NFSET



ELECTRIC
SUBMERSIBLE PUMP



Tea Break..!



Coffee
Break

Let's Take a Break